

Airlinq[®] – Digital BMS

Information Guide

LON[®] modul

Manual

This manual is only for information.

For Programming the Airlinq BMS modul for LONWORKS® you have to use the manual "BMS modul for LONWORKS®".

Airlinq LON BMS module version 5.0

Introduction

The Airlinq LON® version 5.0 expose the Airlinq ventilation unit for a LONWORKS® control network. The purpose is to control the air handling unit (AHU) from LON®-based control organs or from a BMS system, and to get relevant status feedbacks from the AHU.

The related LONMARK® profile document describes the LONWORKS® interface as LONMARK® Functional Profiles where detailed information of each variable is outlined in detail.

To integrate the Airlinq LON® version 5.0 node into a LONWORKS® control network, a XIF file is essential to

present the interface of the Airlinq node for the integration tool. The XIF file is available for download from the Airmaster web site.

The nearby guideline present different minimum setups of the AHU to a LONWORKS® control network. The examples are carried out with use of the Integration tool Echelon® LonMaker®, but similarly tools can be used as well.

Audience

It's recommended that the LON® integration is to be carried out by a person who is familiar with the LONWORKS® technology.

Setup method 1: Minimum requirement solution

Operate the AHU ON and OFF with default settings.

The variable nviOpMode can be used as a control input for start - stop of the AHU. The variable is an enumeration type, and the value 0 (HVAC_AUTO) will

send an automatic ventilation request to the AHU, which will use default values for temperature and airflow. The value 6 (HVAC_OFF) will stop the AHU.

The AHU will use default values for Inlet Temperature and Airflow.

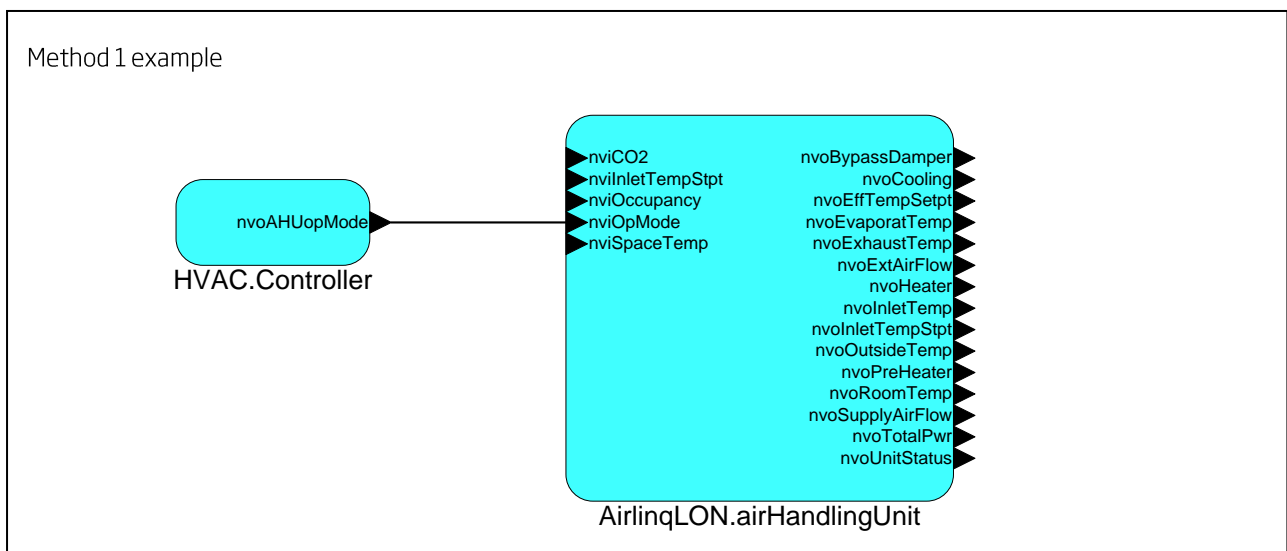

Method 2: Temperature input from a Wall Mounted Temperature Controller, and occupancy controlled

Start - stop of the AHU by an Occupancy Sensor.

An integration of a LON® based Occupancy Sensor in combination with a Temperature Controller with a

temperature setpoint dial, to the Airlinq LON® module forms a minimum control network for air handling in an occupation zone. For this purpose the variable `nviInletTempStpt` and the `nviOccupancy` has to be bound to the sensors.

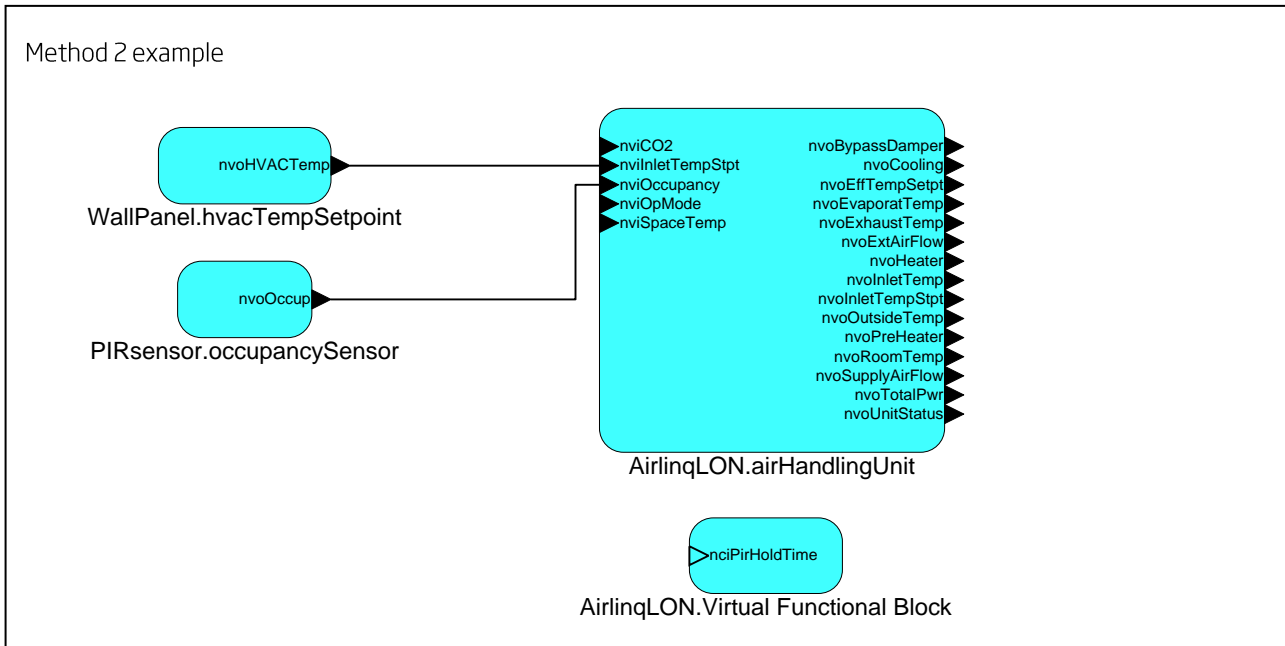

As an option the PIR hold time can be configured via the configuration input `nciPirHoldTime`, where the raw value is in 1/10 seconds, and the LONMARK® formatted

value is presented as `SNVT_time_sec`. The AHU will run the configured holdtime after the last presence detected.

Method 3: Temperature and flow control from a BMS system, with feedbacks from the AHU.

To control the Airlinq AHU from a BMS system the following network variables must be establish on the main computer or at a HVAC controller.

- For controlling the operation mode -- make a NVO of the type SNVT_hvac_mode
- For controlling the airflow -- make a NVO of the type SNVT_lev_percent
- For controlling the Inlet temperature setpoint -- make a NVO of the type SNVT_temp_p

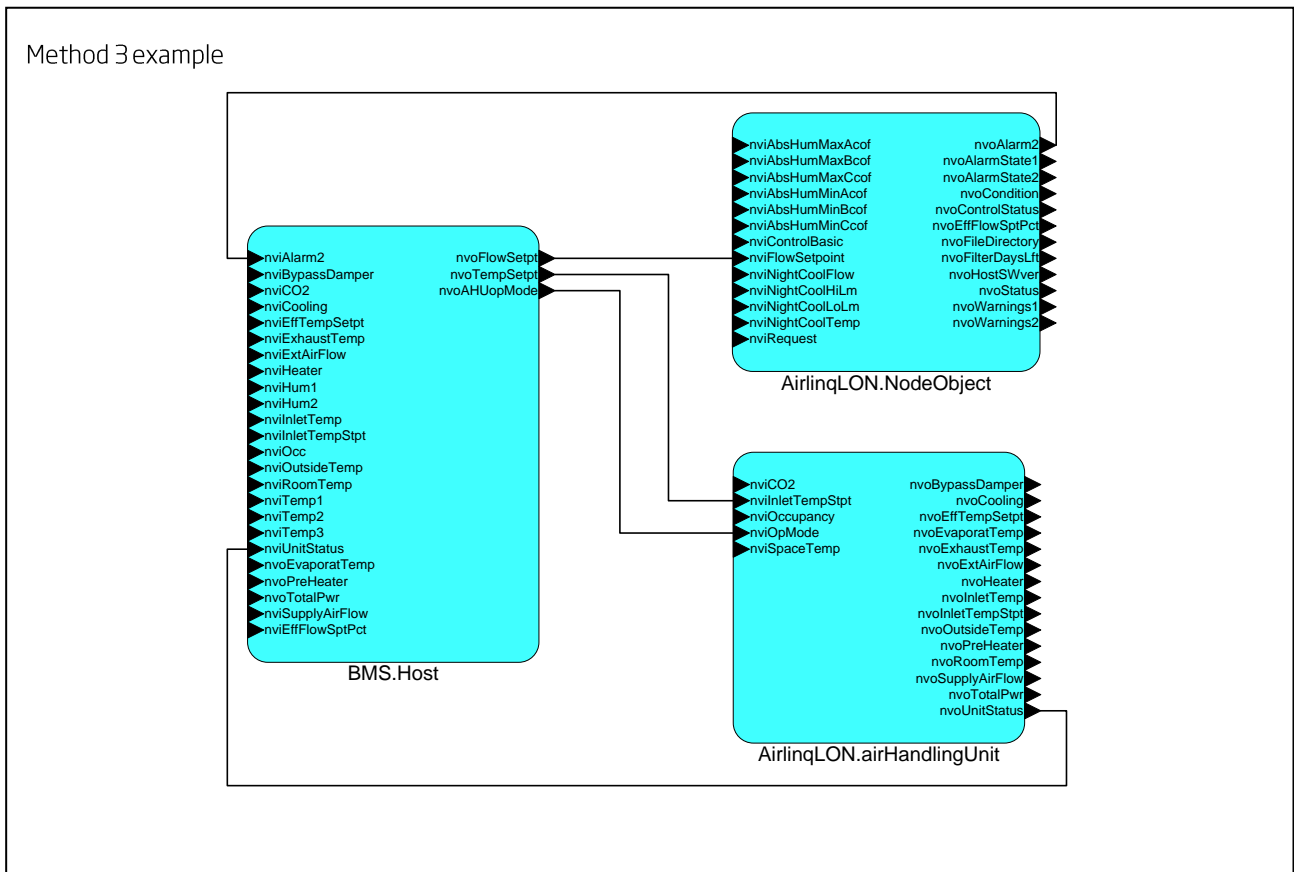

For feedback to the BMS system a lot of status parameters are available, but for an overall health status of the AHU the following NVO's can be monitored.

- For AlarmStatus the nvoAlarm2 of the type SNVT_alarm2 is recommended to be bound to BMS or SCADA system and event logged. Alarms from the AHU are event driven as a structured variable presenting different information about the alarm including a timestamp and a sequence number of the alarm.

- For Actual Operation Mode the nvoUnitStatus of the type SNVT_hvac_status is available. The structured variable presents the actual operation mode in combination to heating and cooling status parameters.

For detailed information about the mentioned network variables, please refer to the Airlinq LONMARK® profile document.

Notes:

Airflow Lufttechnik GmbH
Kleine Heeg 21 ☎ 53359 Rheinbach
Telefon: 022 26/9205-0 ☎ Fax: 022 26/9205-11
info@airflow.de ☎ www.airflow.de

Version Januar 2016 – Änderungen vorbehalten.

